

GANTRY LINE

LARGE-VOLUME COORDINATE MEASURING MACHINES



EXCEPTIONAL EXPERTISE IN LARGE SIZE CMMS

Hexagon Manufacturing Intelligence's success is due to the quality of design and superior mechanical structure of its machines, which are supported by the most advanced technology and an extensive service and support network.



AN ABRIDGED LIST OF HEXAGON GANTRY CMM CUSTOMERS

Active tool	Brenner Tools	Famer	Kamaz	Northrop	Siemens
Alenia Aermacchi	Brittain	Fasa Renault	Kempton Heavy	Nuovo Pignone	Sikorsky
Aerospace	Cadillac Motors	FCA	Ind.	Nurtanio	Skoda
Dynamics	Candemat	First Autoworks	Kitech	Off. Mecc.	Soko
Aerospaziale	Caterpillar	Ferrari FMC	Korean Airlines	Vecchiato	Teledyne
AG International	CFAN	Fokker	Kodak	Ogihara	Three-M Tool & Machine
Airbus	Chengdu Aircraft	Ford	Laepple	Oto Melara	Thyssen
Alcoa	China National	Fuji Heavy	Laser Die	Pegaso	Tianjing Auto Works
Asfo	Aero Technology	GEC Alsthom	Liaoni	Peugeot	Toyota Motorsport
Alfa Romeo	China National	General Electric	Lockheed	Pininfarina	Transwerk
Allison Gas	Erzhong Group	General Motors	Mack Trucks	Plastic Omnium	Uspo
Ansaldo	Chongqing	Giddings & Lewis	Magna	Pratt & Whitney	Unipres
Atomash	Citroën	Hal Bangalore	Major Tool & Machine	PSA	VAZ
Audi	Comau	Hebei	Mares	Radiation System	Vikram
Austin Morris	Cone Blanchard	Hes Makina	Mazda	Ratier	Volkswagen
Autolatina	Contraves	Sanayi	MBB	Renault	Volvo
Avion Complex	CPC	Hispano Bugatti	McDonnell	Rockwell	Vought
Becker	Csepel	Honda	Douglas	Rolls Royce	Weingarten
Bell Helicopters	Cummins	Hongdu Aviation	Milford	Rover	Westland
Benteler	Daimler Benz	Hyundai	Mitsubishi	Rust International	World Aerospace
Berardi	Dacia	Ideal Tool	Modelmaster	SAAB Skania	Xian Aero Engine
Beretta	Daewoo	Induplan	Modelos Aparicio	Sabca	Ynuma Machinery
BMW	Danieli	Isotta Fraschini	MTU	Sanyo	ZAZ
Bisiach & Carru	Devlieg	Italdesign	NCR Datong	Saturn	ZCZ
B.O.C.	Dismodel	Italstampi	Electric	SEAT	ZIL
Boeing	Dostel Makina	Janar Tool	Locomotive	Sebewaing	
Bofors	EADS (Casa	John Deere	Nissan	Sermati	
BP Chemicals	Espacio)	Jupasa	Ningbo	Sevel	
BPD	Exco	Kalt		Shin Meiwa	

HEXAGON MANUFACTURING INTELLIGENCE THE BIG NAME IN GANTRY CMMS

Forty years of experience in designing, manufacturing and marketing CMMs and an installed base of over 1 900 gantry machines in 42 countries has secured Hexagon's position of world leadership in large-size CMMs.

Revolutionary through the years since the 1960s.

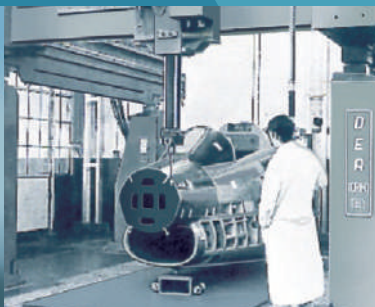
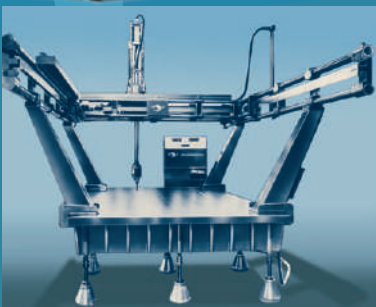



DEA ALPHA 2.0

BRIDGING THE PRICE / PERFORMANCE GAP IN GANTRY CMMs

An innovative product line of cost-effective, medium-capacity multisensor gantry CMMs, the DEA ALPHA 2.0 combines high throughput and high accuracy with excellent operating reliability and minimal maintenance.

DEA ALPHA 2.0 is available in two versions, DEA ALPHA 2.0 Classic, and DEA ALPHA 2.0 Performance.

DEA ALPHA 2.0 Classic is an all-purpose flexible CMM for the dimensional inspection of large castings and machined parts. Equipped with a high-productivity 3D scanning laser head and continuous servo wrist options, DEA ALPHA 2.0 Classic can rapidly acquire millions of data points from complex contoured shapes, and is the ideal system for die and mould manufacturing support.

DEA ALPHA 2.0 Performance is a high-performing gantry CMM that, thanks to a high-rigidity silicon carbide spindle and a sophisticated multisensor temperature compensation system, guarantees high accuracy and ease of use under all operating conditions.

All DEA ALPHA 2.0 models can be supplied equipped with optional bellows and covers, which offer machine protection for airborne shop contaminants.

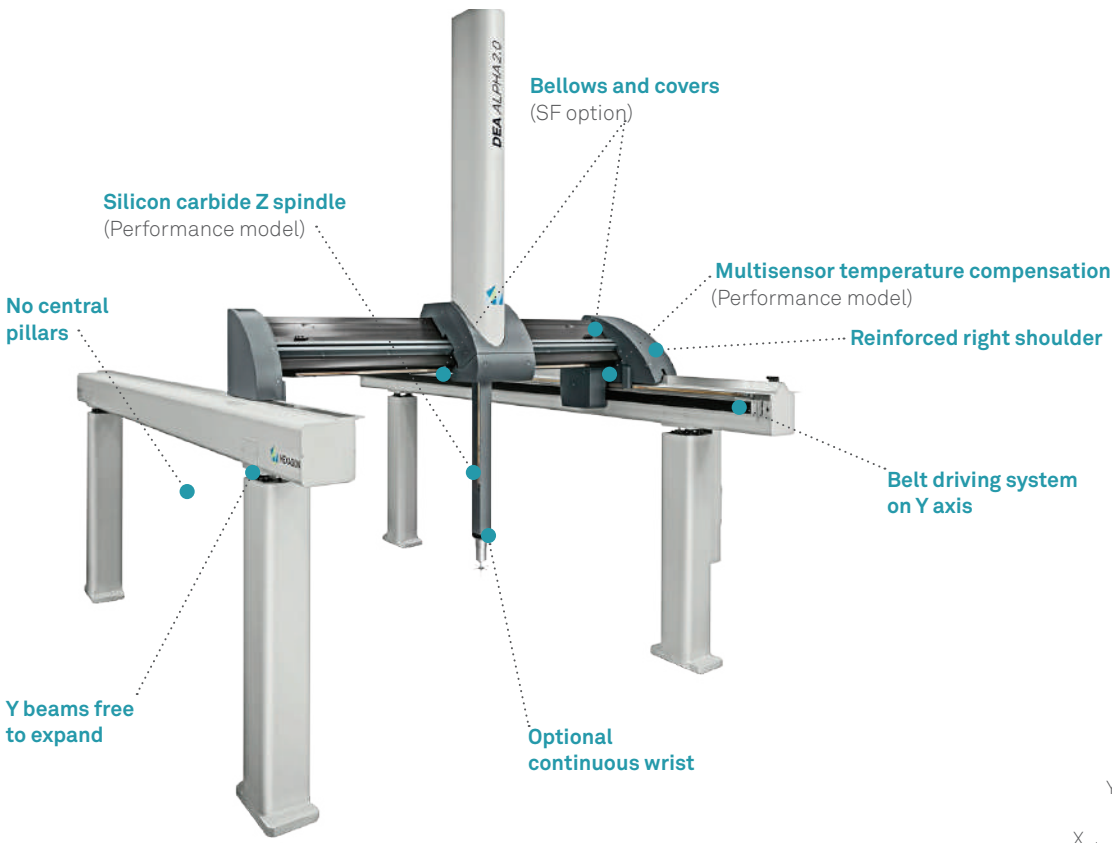

DEA DELTA SLANT

THE PERFORMANCE STANDARD IN GANTRY CMMS

DEA DELTA SLANT is a mid- to large-sized gantry coordinate measuring machine that is the outcome of the many years' experience offered by Hexagon in the design and construction of gantry CMMs.

Thanks to years of engineering expertise, DEA DELTA SLANT offers a range of sizes and accuracies at unbeatable price/performance ratios. DEA DELTA SLANT adopts Hexagon's latest technological innovations, like

the main X traverse beam made of extruded aluminium with patented TRICISION® design, dual reader on the Y beams, as well as the most advanced automatic compensation system for geometric errors, that handles 26 different parameters (Performance version). All DEA DELTA SLANT models are equipped with a structural multisensor temperature compensation. DEA DELTA SLANT is available in two versions, DEA DELTA SLANT Classic and DEA DELTA SLANT Performance.

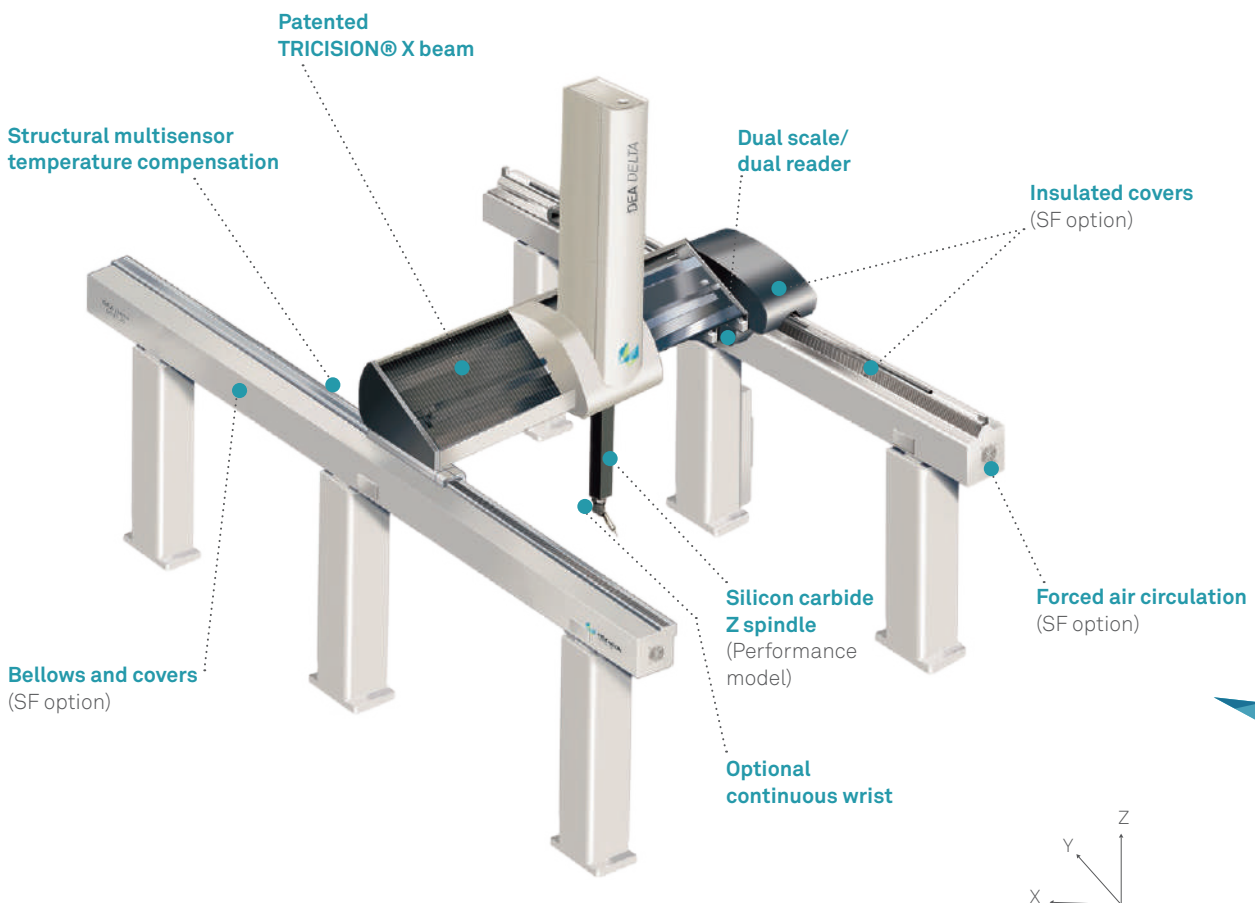

The flexible DEA DELTA SLANT Classic measurement system is a perfect blend of metrology performance, versatility and affordability.

DEA DELTA SLANT Performance is the ideal system for applications requiring higher accuracies and shorter measurement cycles. The typical applications of DEA DELTA SLANT are mid- to large-sized components of the automotive, aerospace, heavy transport, railway, wind energy and die and mould industries.

DEA DELTA SLANT has the whole range of Hexagon probes and probe heads available – from the versatile and effective indexable probe heads range, through the fixed continuous scanning heads, to the HH-ACW-43MW continuous wrists.

To allow the use of DEA DELTA SLANT systems in industrial environments without air-conditioned enclosures, all models may be configured in the Shop Floor (SF) version. This specialised kit consists of covers and bellows for the whole machine structure, including the forced ventilation along longitudinal beams.





DEA LAMBDA

HEAGON

21

DEA LAMBDA SP

THE HI-TECH GIANT CMMS

DEA LAMBDA SP is a line of very large measuring machines designed for operation in industrial environments. They excel in the high-speed, high-accuracy inspection of huge components, such as marine engines, aircraft structures and turbines, that require open, modular, easily customisable structures with virtually unlimited measuring volumes.

A proprietary dual drive/dual encoder system on the Y axis simulates a virtual single axis located at the centre of the carriage. Carriage yawing and structure deformations during motion are monitored by a distributed sensor system and compensated in real time. This unique configuration prevents the yawing of the carriage, ensuring higher dynamics and superior measuring accuracy.

All axes and pillars are protected by wraparound thermally insulated covers and bellows. Internal forced air circulation eliminates temperature stratification. An advanced multisensor temperature compensation system ensures nominal measuring accuracy over an extended ambient temperature range. High-performance servo wrist options handle exceptionally long probe extensions for full accessibility to all part features.

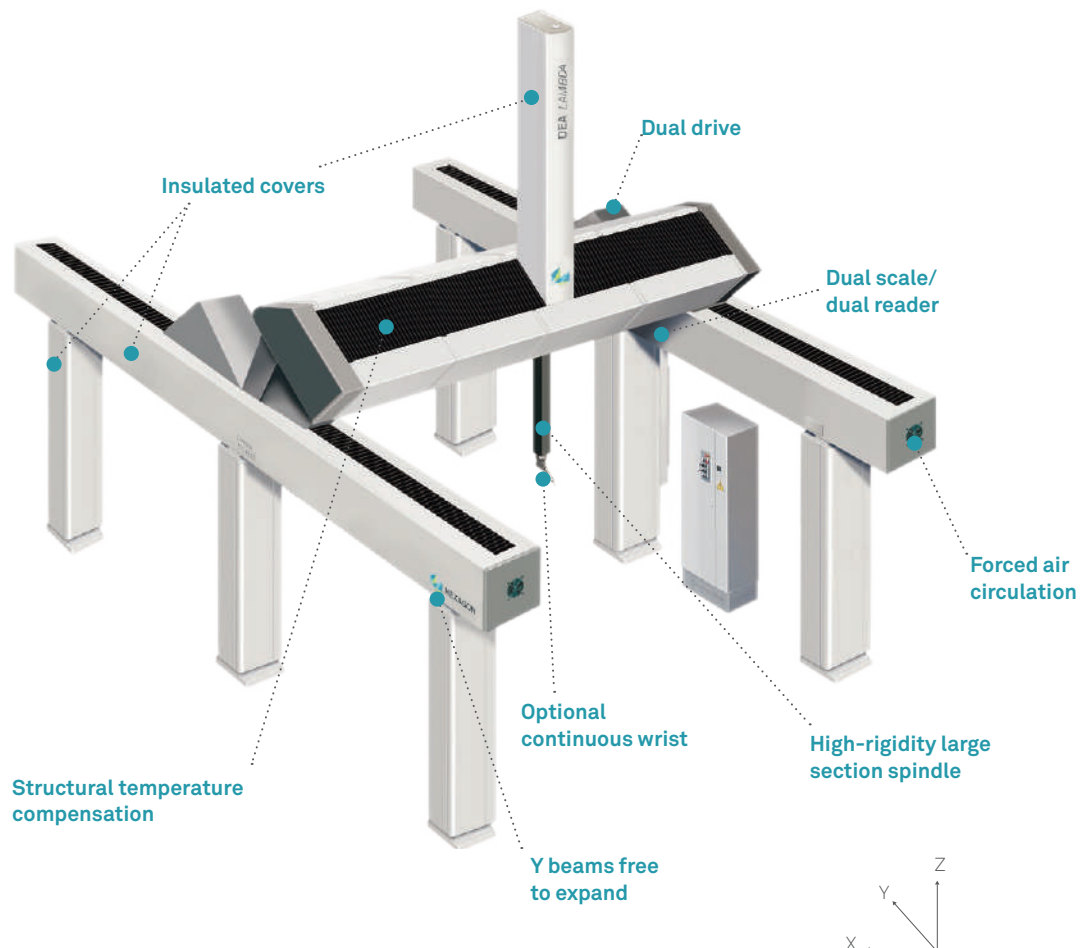

SOPHISTICATED TECHNOLOGY

SUPERIOR LONG-TERM ACCURACY

- Conservative FEA design reduces structural deflections
- Real-time correction of up to 26 geometrical parameters (DELTA SLANT Performance)
- Extra-large bearing proportions and generous stiffness/mass ratio
- High-rigidity large section Z spindle
- High-resolution scales
- Vibration isolation options

EXCELLENT PRODUCTIVITY AND FLEXIBILITY

- Low-mass aluminium alloy moving members
- Maximum acceleration – control of jerk
- Continuous motion interpolation
- Automatic optimised tuning of servo parameters
- High-throughput non-contact sensor options
- Optional servo wrist rotates while the machine moves
- Integrated flexible fixturing options

RELIABLE DESIGN FOR EFFECTIVE INTEGRATION

- Lower maintenance requirements
- High calibration stability
- Reduced field adjustments
- Easy access to all machine components
- Wear- and damage-free use

EXTENDED SYSTEM AVAILABILITY

- Proven heavy-duty machine design
- Multiple enclosure options
- Partial/full covers
- Thermally insulated
- Pneumatic safety brake on the Z spindle
- Industry standard compliance

SAFE OPERATION IN WORKSHOP ENVIRONMENTS

- Y axis guideways are free to expand without distorting
- Scales with certified coefficient of temperature expansion
- Thermally stabilised machine versions
- Thermally-insulated enclosure versions
- High-efficiency temperature compensation

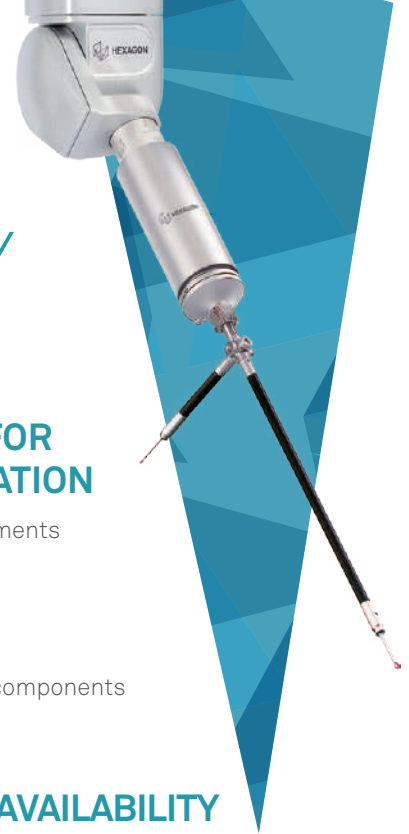

DIVERSE FIELDS OF APPLICATION

DIE AND MOULD MANUFACTURING

Hexagon's gantry machines provide an advanced tool for model making, die prove-out, inspection analysis and failure analysis.

- High-accuracy, high-productivity surface mapping capabilities are supported by automatic tactile scanning systems and ultra-high-speed non-contact scanning head options that acquire millions of data points from the model real surface
- Efficient CAD interfaces allow the export of processed surface point files to CAD/CAM systems for the generation of machining tool paths

SURFACE DESIGN AND METROLOGY

An interactive computer graphic environment for the dimensional verification and CAD modelling of freeform surfaces streamlines:

- Reverse engineering operations for the creation, maintenance and modification of CAD models directly from actual parts
- The efficient incorporation of design and manufacturing changes back into the CAD database
- The quick and complete verification of complex freeform shapes and features directly from their nominal CAD geometry

DIMENSIONAL INSPECTION

Hexagon's gantry machines excel in inspecting large and very large mechanical parts, high-precision machined components, and large automotive and aerospace structures, all with superior accuracy. The application is supported by:

- A complete metrology CAM package: bi-directional direct CAD interfaces allow establishing common manufacturing practices driven from CAD databases
- An interactive graphic user interface, that includes a 3D animation of the full machine kinematics including part and fixtures, and flexible graphical reporting functions
- Advanced scanning options that increase data point density and improve feature dimension, location and form analysis, while enhancing system throughput

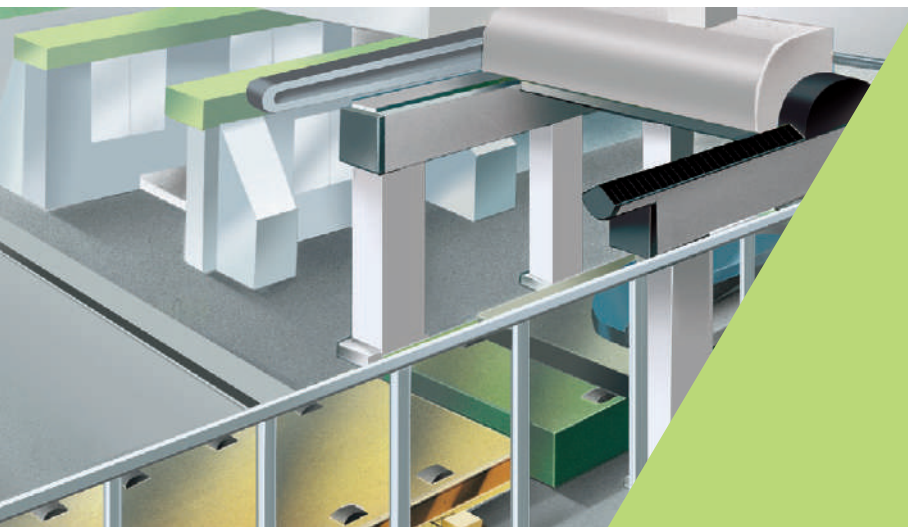

PROBING THE DIFFERENCE

A WIDE RANGE OF HIGH-PERFORMANCE PROBE HEADS AND MEASUREMENT SENSORS

HH-A-T5°

HH-A-T5° is a motorised articulating probe capable of rotating two axes in 5° increments, which translates to a total of 2 952 possible positions. The robust aluminium construction and rugged design permits extension rods with lengths over 300 mm. The TKJ kinematic joint connection allows direct docking with continuous scanning probes or, coupled with an M8 adaptor, it can be used with HP-TM touch trigger probes as well as probes from other manufacturers.

HH-A-2.5

The HH-A-2.5 is a motorised probe head in the Hexagon sensor line; the head features a number of innovations including an embedded controller and capacitive crash protection, while positioning is achieved by use of a Hirth gear. The HH-A-2.5 also benefits from a completely redesigned drive system. The HH-A-2.5 is available in two versions:

- **HH-A-T2.5 AUTOMATIC TKJ PROBE HEAD**
The head is fitted with a kinematic joint (TKJ) that can be connected to a multiwire to give multisensor support. The TKJ can be changed either manually or automatically (with the HR-R probe changer) without the need for requalification. The probe is capable of indexing in 2.5° increments and can achieve 12 240 unique positions.
- **HH-A-H2.5 AUTOMATIC HDKJ PROBE HEAD**
The head is fitted with the Heavy Duty Kinematic Joint (HDKJ), which can carry extensions of up to 750 mm and can also be connected to a multiwire to give multisensor support. Laser scanner and analogue scanning heads can be supported further from the axis of rotation than with conventional heads due to the combination of extreme rotational torque and the design of the HDKJ adaptor. The HDKJ can be changed either manually without the need for requalification or automatically with the HR-R tool changer fitted with the optional HR-RH Heavy Duty Module. The probe is capable of indexing in 2.5° increments and can achieve 20 736 unique positions.

HP-S-X5

Ultra-precise, full 3D, fixed scanning head capable of simultaneously measuring in the X, Y, and Z directions to precisely define the orientation of the workpiece surface. This heavy-duty analogue probe features very high and repeatable accuracy even with extra-long probe extensions and heavy styli clusters (up to 500 mm in length and 500 g in weight, the HD version with extension up to 800 mm is available on request). It features a proprietary anti-collision system offering extra protection for the head. An automatic tool changing capability allows styli changes within a measuring program without the need for probe requalification.

HP-S-X1

The HP-S-X1 is a high-accuracy 3D scanning sensor that can take thousands of points quickly and automatically. The HP-S-X1 allows a thorough evaluation of the measured geometric features, including form, position and size error. It is offered in two different probe types, HP-S-X1S and HP-S-X1H, each optimised for specific styli length ranges. This sensor uses the same technology as other probe heads in the HP-S-X range. Thanks to the TKJ adapter, HP-S-X1 can be changed using the HR-R probe changer rack, while fast and repeatable styli changes are possible with the HP-S-X1 styli changer rack due to the magnetic stylus holder.

PC-DMIS

LEADING-EDGE MEASUREMENT SOFTWARE

Available in three different versions and with a number of optional packages, PC-DMIS measurement and inspection software provides the most comprehensive solution to any kind of metrology applications.

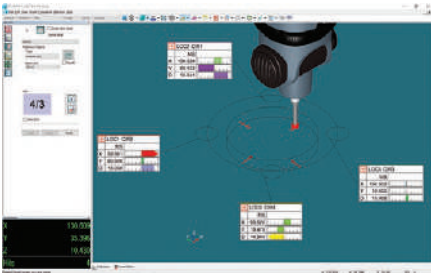

PC-DMIS PRO

Complete Metrology Software

PC-DMIS PRO provides the basic intuitive graphic user interface (without CAD), including a suite of wizards to help operators quickly learn and manipulate key inspection functions. Features include:

- A full programming environment including high level programming functions
- Customisable menus
- Quick Start routines for probe qualifications, part alignments and hyper-reporting functions
- Intuitive Probe and Go to automatically recognise feature types and create interactive graphical part representations

PC-DMIS CAD

Adds the Ability to Import CAD Files

PC-DMIS CAD includes all PC-DMIS PRO functionalities, plus:

- Full 3D animation capability including digitised images of parts and fixtures on the machine so operators can visually verify the setup and program prior to actual part inspection
- Unknown part documentation to generate computer models for reverse engineering applications
- Native download of VDAFS, IGES, DXF, DWG, STEP, XYZIJK, STL, DES and DMIS formats
- A Direct CAD Interface (DCI) option to create part programs directly from CAD models utilising the native CAD system algorithms and tools
- A Direct CAD Translator (DCT) option allows the use of a native CAD model even when the specific CAD system is not owned by the user

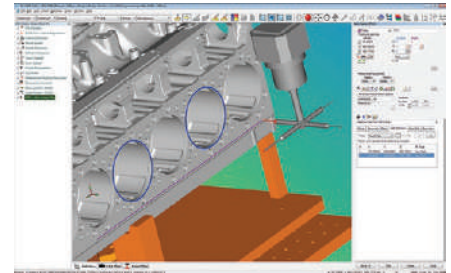

PC-DMIS CAD++

Adds Scanning and Thin-Walled Parts

In addition to all PC-DMIS PRO and PC-DMIS CAD functionalities, PC-DMIS CAD++ incorporates scanning and digitising functions that allow fast and efficient measurement of complex shapes such as turbine blades, dies, models, sheet metal components and other curved shapes. Features include:

- Rotary, patch, linear open and closed loop scanning
- Perimeter, section, UV and edge point scanning
- Complete probe simulation
- Full thin-wall feature measurement suite

DEA ALPHA 2.0



Series	Strokes (mm)			Overall Dimensions (mm)			Weight (kg)
	X	Y	Z	Width	Length	Height	
20.33.10	2000	3300	1000	3460	4280	3560	3100
20.33.15	2000	3300	1500	3460	4280	4560	3400
20.50.15	2000	5000	1500	3460	5980	4560	4000
25.33.15	2500	3300	1500	3960	4280	4560	3500
25.50.15	2500	5000	1500	3960	5980	4560	4000
25.33.18	2500	3300	1800	3960	4280	4860	3500

DEA DELTA SLANT

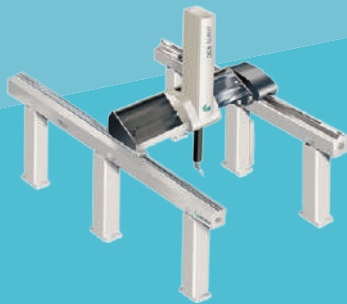

Series	Strokes (mm)			Overall Dimensions (mm)			Weight (kg)
	X	Y	Z	Width	Length	Height	
25.51.20	2500	5100	2000	4367	6504	5604	7150
30.51.20	3000	5100	2000	4867	6504	5604	7250
30.51.25	3000	5100	2500	4867	6504	6604	7850
30.63.25	3000	6300	2500	4867	7704	6604	8350
30.80.25	3000	8000	2500	4867	9404	6604	10450
30.51.30	3000	5100	3000	4867	6504	7604	8500
30.63.30	3000	6300	3000	4867	7704	7604	9100
30.80.30	3000	8000	3000	4867	9404	7604	11350
35.51.25	3500	5100	2500	5367	6504	6404	7850
35.63.25	3500	6300	2500	5367	7704	6404	8450
35.80.25	3500	8000	2500	5367	9404	6404	10550
40.51.30	4000	5100	3000	5867	6504	7640	8650
40.63.30	4000	6300	3000	5867	7704	7640	9250
40.80.30	4000	8000	3000	5867	9404	7640	11400

DEA LAMBDA SP

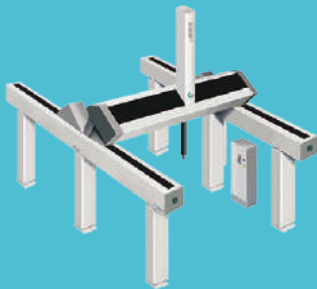

Series*	Strokes (mm)			Overall Dimensions (mm)			Weight (kg)
	X	Y	Z	Width	Length	Height	
40.51.30	4000	5100	3000	6345	7530	8290	11800
40.63.30	4000	6300	3000	6345	9000	8290	12400
40.80.30	4000	8000	3000	6345	10600	8290	15300
40.100.30	4000	10000	3000	6345	13200	8290	16950
50.51.35	5000	5100	3500	7345	7530	8790	13000
50.63.35	5000	6300	3500	7345	9000	8790	13600
50.80.35	5000	8000	3500	7345	10600	8790	16500
50.100.35	5000	10000	3500	7345	13200	8790	18150
60.51.40	6000	5100	4000	8345	7530	9290	14200
60.63.40	6000	6300	4000	8345	9000	9290	14800
60.80.40	6000	8000	4000	8345	10600	9290	17700
60.100.40	6000	10000	4000	8345	13200	9290	19350

*Approximate sizes for DEA LAMBDA SP

A STANDARD OF QUALITY SECOND TO NONE

The quality and reliability of Hexagon's gantry CMMs results from the accuracy of the manufacturing techniques and total quality control procedures adopted, plus the rational interaction of skilled workers with high-technology production equipment.

FULL MACHINE PERFORMANCE CERTIFICATION

The performance of all machines is checked and certified through the most rigorous application of the test procedures specified by stringent international standards for CMMs (ISO, ASME, VDI/VDE). The tests include:

- The verification of the maximum permissible error of indication for size measurement
- The verification of the maximum permissible probing error
- The verification of the maximum permissible scanning probing error

A COMMITMENT TO QUALITY

The company's exclusive Quality Information System (QIS) monitors in real time the quality of each machine produced and its compliance with the specified standards.

All aspects of the activity carried out by Hexagon, from product design and manufacturing to delivery and customer service, have been reviewed and found to meet internationally-accepted quality standards.



ISO 14001 ISO 9001 VDA 6.4

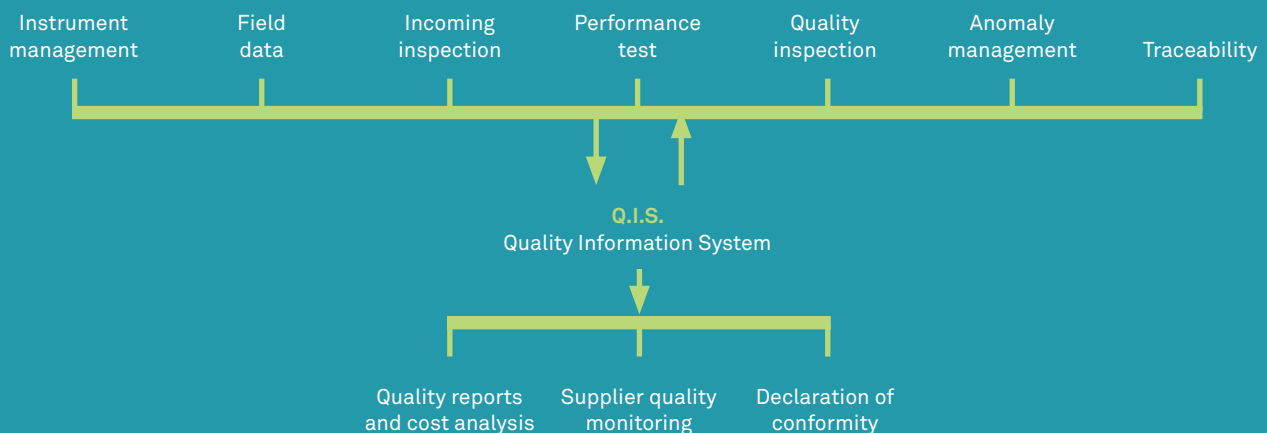





Hexagon Manufacturing Intelligence helps industrial manufacturers develop the disruptive technologies of today and the life-changing products of tomorrow. As a leading metrology and manufacturing solution specialist, our expertise in sensing, thinking and acting – the collection, analysis and active use of measurement data – gives our customers the confidence to increase production speed and accelerate productivity while enhancing product quality.

Through a network of local service centres, production facilities and commercial operations across five continents, we are shaping smart change in manufacturing to build a world where quality drives productivity. For more information, visit HexagonMI.com.

Hexagon Manufacturing Intelligence is part of Hexagon (Nasdaq Stockholm: HEXA B; hexagon.com), a leading global provider of information technologies that drive quality and productivity across geospatial and industrial enterprise applications.

-  COORDINATE MEASURING MACHINES
-  3D LASER SCANNING
-  SENSORS
-  PORTABLE MEASURING ARMS
-  SERVICES
-  LASER TRACKERS & STATIONS
-  MULTISENSOR & OPTICAL SYSTEMS
-  WHITE LIGHT SCANNERS
-  METROLOGY SOFTWARE SOLUTIONS
-  CAD / CAM
-  STATISTICAL PROCESS CONTROL
-  AUTOMATED APPLICATIONS
-  MICROMETERS, CALIPERS AND GAUGES
-  DESIGN AND COSTING SOFTWARE