

Starrett®



VISION SYSTEMS

AV SERIES

AV300+

AV350+

AV450+

METROLOGY SOLUTIONS

STARRETT VISION SYSTEMS

RUGGED, ACCURATE & EASY TO USE

The Starrett automatic vision (or video-based) metrology systems provide accurate 3-axis measurement capability (X-Y-Z) with hi-resolution video zoom optics. The systems can be pre-programmed (CNC) for repetitive part inspection, or driven manually via a joystick and trackball for individual measurements. Superb performance is achieved by a highly stable mechanical design, with precision linear bearings. Throughput is maximized with either QC5000 or Metlogix M3 software controlling all aspects of Video Edge Detection (VED) and multiple channel Fiber Optic or LED illumination.

Starrett automatic vision (AV) systems are ideal for quality assurance, parts inspection, and production runs. Flexible and powerful the AV series allows users to cost effectively achieve maximum throughput of their inspection process, allowing measured data to be effectively archived or networked to other devices.



AV DIMENSIONS

Unit dimensions, H x W x D:

AV300 27.5 x 23 x 25" (70 x 58 x 63 cm)

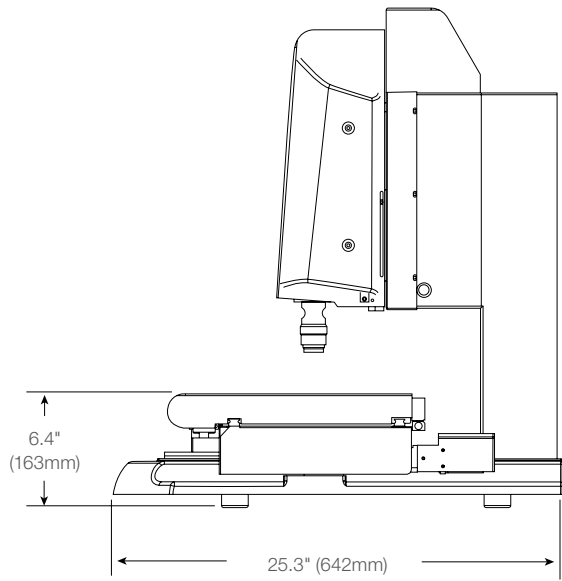
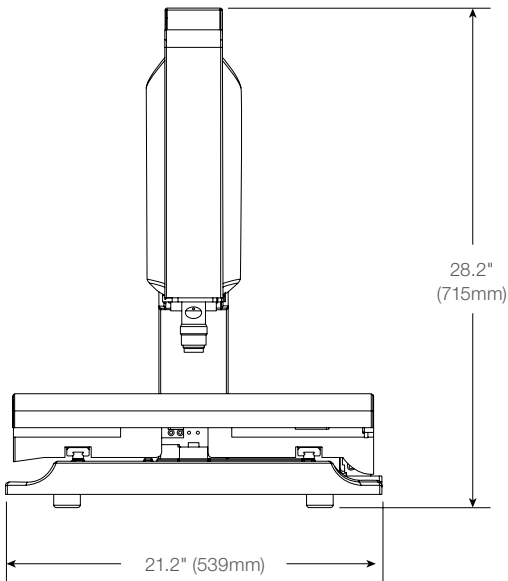

AV350 AND AV450 27.5 x 23 x 25" (70 x 58 x 63 cm)

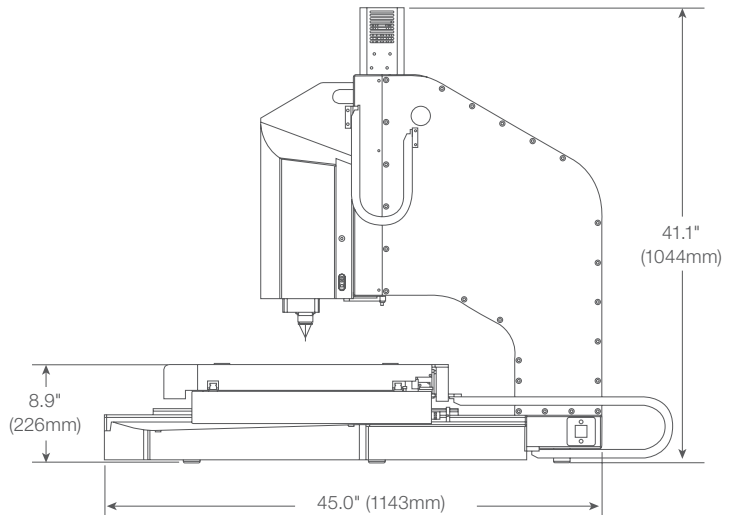
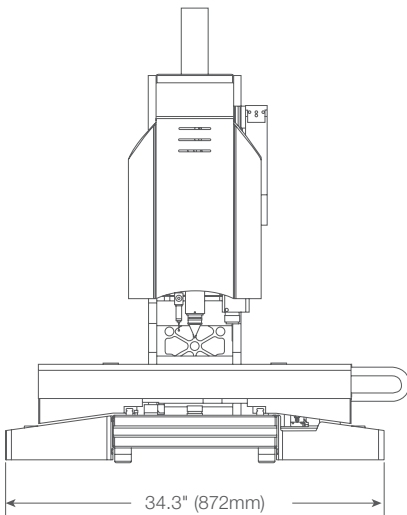

Starrett Metrology Division

Starrett Kinematic Engineering, Inc.
26052-103 Merit Circle
Laguna Hills, CA USA 92653
Tel: 949-348-1213



Starrett.com

AV300-350

Bulletin 967

PDF 09/17

The L.S. Starrett Company 2017®
Specifications Subject to Change

Starrett®

AV300 ▲ AV350 ▲ AV450



AUTOMATIC VISION METROLOGY SYSTEMS

The AV Vision System consist of three models, AV300 with 12 x 6 x 5.5" (300 x 150 x 140mm), the AV350 with 14 x 14 x 8" (350 x 350 x 200mm), and the AV450 with 18 x 14 x 8" (450 x 350 x 200mm). Stage movement can be controlled by pre-programmed measurement routines or manually by joystick/trackball. These benchtop vision metrology systems are easy to use, versatile and accurate. They are equally suitable for individual measurements, short runs, and large production runs.



FEATURES

- CNC operation or manual operation via joystick and trackball
- AV300 12 x 6 x 5.5" (300 x 150 x 140mm)
- AV350 14 x 14 x 8" (350 x 350 x 200mm)
- AV450 18 x 14 x 8" (450 x 350 x 200mm)
- AV300, E2 = 1.9 μm + 5L/1000 accuracy for X and Y, E1 = 2.5 μm + 5L/1000 for Z
- AV350 / AV450, E2 = 2.5 μm + 5L/1000 accuracy for X and Y, E1 = 2.5 μm + 5L/1000 for Z
- 20 μin (0.5 μm) reading resolution with M3 software, 4 μin (0.1 μm) with QC5000 software
- Magnification on 24" monitor, 1:1 pixel setting: 37X to 240X with 6.5:1 zoom, 25X to 240X with 12:1 zoom
- Multiple channel Fiber Optic or LED Illumination
- Cast aluminum base for AV300. Granite base AV350
- 1.3 megapixel digital color camera

LENS OPTIONS

- 6.5:1 or 12:1 zoom optics
- Optional 0.5X, 1.5X and 2.0X auxiliary lenses

OPTIONS

- Renishaw touch probe
- Ergonomic workstation (standard on AV350 / AV450)
- 0.5X, 1.5X and 2.0X auxiliary lenses for zoom optics
- LED darkfield quadrant illuminator
- 2 or 4 bay touch probe change rack

OPERATOR INTERFACE The AV300, AV350, and AV450 are available with an all-in-one touch-screen PC with MetLogix M3 DXF/FOV/CNC software, or with a desktop PC with an external monitor and QC5000 software. The M3 software supports 2D geometrical constructs (lines, angles, circles), while the QC5000 software also supports 3D constructs (inclined planes, cones, spheres).

FEATURE	MetLogix M3	QC5000
All-in-one PC with touch-screen	x	
Desktop PC with monitor		x
External motion control unit	x	x
Windows® operating system	x	x
Wi-Fi network connectivity	x	x
CAD file import and export	x	x
Video edge detection	x	x
X-Y-Z measurements	x	x
2D geometric constructs	x	x
3D geometric constructs		x
CNC control capability	x	x
Report generation and archiving	x	x
Software developer	MetLogix	Metronics / Heidenhain



AV OPTICS

The AV300, AV350, and AV450 include motorized/programmable zoom lenses with magnification ranges of 6.5:1 or 12:1. The two zoom lenses are available with auxiliary lenses to multiply magnification by 0.5X, 1.5X or 2.0X.

ACCESSORIES

Starrett manufactures a comprehensive range of fixtures and accessories for our line of optical and vision metrology systems.



Glass Calibration Standard



Machine Pedestals
Standard on AV350 / AV450